

Stückliste /Parts List **599 356 5205L**

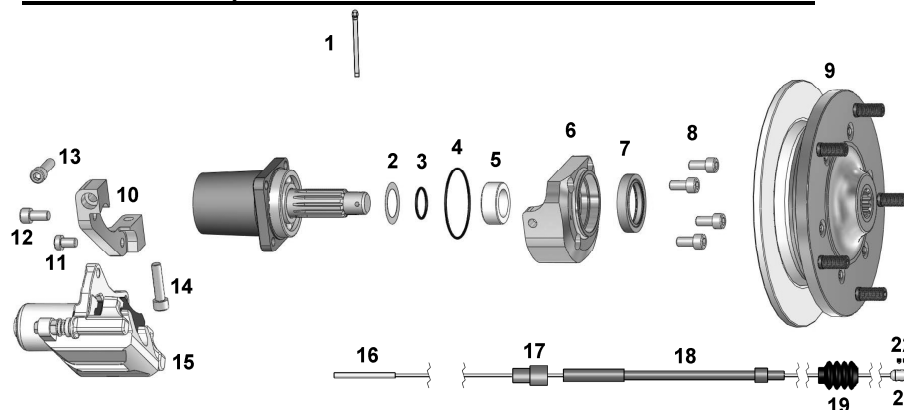

Position Number	Bestell-Nr. Part-#	Bezeichnung Description	Anzahl Quantity
1	012 548 N1	Splint 5x71 <i>Split pin</i>	2
2	598 051 311	Dichtsatz Hinterachse <i>Sealing kit, rear axle</i>	2
3	598 051 311	Dichtsatz Hinterachse <i>Sealing kit, rear axle</i>	2
4	598 051 311	Dichtsatz Hinterachse <i>Sealing kit, rear axle</i>	2
5	501 303 175	Distanzring Radlager 17,5mm <i>Wheel Bearing Spacer, 17.5mm</i>	2
6	501 311 356 -1	Radlagerdeckel links <i>Wheel Bearing Cap, Left</i>	1
6a	501 312 356 -1	Radlagerdeckel rechts <i>Wheel Bearing Cap, Right</i>	1
7	598 051 311	Dichtsatz Hinterachse <i>Sealing kit, rear axle</i>	2
8	009 0912 1020	Schraube DIN 912, M10x20, 10.9 <i>Bolt for Wheel Bearing Cap, DIN 912, M10x20, 10.9</i>	8
9	X501 581 356L	Radnabe kompl. 356, links <i>Aluminium Hub Assembly, 356, LH</i>	1
9a	X501 582 356L	Radnabe kompl. 356, right <i>Aluminium Hub Assembly, 356, RH</i>	1
10	501 311 356 -2	Bremssattelhalter links <i>Caliper Bracket, Left</i>	1
10a	501 312 356 -2	Bremssattelhalter rechts <i>Caliper Bracket, Right</i>	1
11	009 6912 10F16	Schraube DIN 6912, M10x1,25x16, 10.9 <i>Bolt for Caliper, DIN 6912, M10x1.25x16, 10.9</i>	2
12	009 0912 10F20	Schraube DIN 912, M10x1,25x20, 10.9 <i>Bolt for Caliper, M10x1.25x20, 10.9</i>	2
13	009 0912 10F35	Schraube DIN 912, M10x1,25x35, 10.9 <i>Bolt for Caliper Bracket, DIN 912, M10x1.25x35, 10.9</i>	2
14	009 0912 10F40	Schraube DIN 912, M10x1,25x40, 10.9 <i>Bolt for Caliper Bracket, DIN 912, M10x1.25x40, 10.9</i>	2
15	698 515 356CSP	Bremssättel mit Belägen, hinten <i>Calipers with pads, rear</i>	1
16	609 721 2000356	Handbremsseil, 2000mm <i>Handbrake cable, 2000mm</i>	2
17	609 722 356	Distanzstück <i>Spacer</i>	2
18	609 721 356	Handbremsseilhülle <i>Conduit</i>	2
19	609 722 003	Faltenbalg <i>Rubber grommet</i>	2
21	721 349 000	Klemmstück HBS <i>Wire stop</i>	2
22	009 0914 0506A2	Gewindestift DIN914 M5x6 A2 <i>Allen head screw M5x6 A2</i>	6
ohne Abb.	501 221 311	Kronenmutter <i>Castle Nut</i>	2
ohne Abb.	611 700 356	Bremsschlauch <i>Brake Hose</i>	2
ohne Abb.	611 800 000	Hohlschraube, M10x1 <i>Banjo bolt, M10x1</i>	2
ohne Abb.	009 7603 1014	Dichtring, Kupfer 10x14mm <i>copper washer, 10x14mm</i>	4
ohne Abb.	012 150 01025	Innensechskantschlüssel, 2,5mm <i>Allen hex key, 2.5mm</i>	1
ohne Abb.	000 604 SS	Schraubensicherungsmittel <i>Loctite</i>	1

Stand: Okt-14

Datum / Date: _____

zusammengestellt von / pulled by : _____